

# **Silicon Controlled Rectifier (SCR)**

## **Lecture – 14**

**TDC PART – I**

**Paper - II (Group - B)**

**Chapter - 5**

**by:**

**Dr. Niraj Kumar,**

**Assistant Professor (Guest Faculty)**

**Department of Electronics**

**L.S. College, BRA Bihar University,  
Muzaffarpur.**

# Silicon Controlled Rectifier (SCR)

## Lecture – 14

TDC PART – I

Paper - II (Group - B)

Chapter - 5

- **SCR Turning-OFF Methods (PART – 2)**
- **Lecture Content :-**
  - (1) **Natural Commutation**
  - **Natural Commutation of SCR**
  - **Natural Commutation of SCR Explanation**

# (1) Natural Commutation

- “In **Natural Commutation**, the source of **Commutation Voltage** is the **Supply Source Voltage** itself. If the SCR is connected to an **AC Supply**, at every end of the **Positive Half Cycle** the **Anode Current** goes through the **Natural Current Zero** and also immediately a **Reverse Voltage** is applied across the **SCR**. These are the conditions to **Turn-OFF** the **SCR**”.

- **Natural Commutation of SCR** is the process of **Turning-OFF** an SCR without using any external additional **Commutation Circuitry** or The process of **Turning-OFF** a SCR (thyristor) without using any **External Circuits** is known as **Natural Commutation**. This type of **Commutation** is possible in the application where the **source of supply is AC Source**. **Natural Commutation** occurs only in **AC Circuits**, and it is named so because it doesn't require any **External Circuit**.

- When using **AC Supply**, the current passing through the SCR device is **Alternating**. This **Alternating Current (AC)** go to **peak positive value** in **Positive Half Cycle**, then it passes through **zero** and then go through **peak negative value** in **Negative Half Cycle**.  
When, the **Positive Half Cycle** of **Alternating Current** reaches at **zero**, then the **Anode Current** passing through the SCR device also become **zero** naturally at every end of the **Positive Half Cycle**.

- Now after the completion of **Positive Half Cycle** of **Alternating Current**, **Negative Half Cycle** of **Alternating Current** starts. Now again immediately at same time in **Negative Half Cycle** a **Reverse Polarity (Voltage)** develop across the **SCR (thyristor)**. This **Reverse Anode to Cathode Voltage** (the **Cathode is Positive** with respect to the **Anode**) will tend to **interrupt the Anode Current of the SCR**. In **AC circuit** the **Source Voltage** reverses in every **Negative Half Cycle**, so that an **SCR in the line** would be **Reverse Biased in every Negative Cycle** and would quickly **Turn-OFF** the **SCR (thyristor)**.

- This process of commutation is known as **Natural Commutation** as no external circuits or components are used in. **This process of commutation is also called Phase Commutation or AC Line Commutation.**
- This method is only applicable when using **AC Supply**. This is not possible to get this work in **DC Supply**, because **DC Supply** is a **unidirectional quantity** and **doesn't change its direction** as a result there is no change in **polarity voltage** that is required to **Turning OFF the SCR (thyristor).**

- A **Natural commutation** is possible with line **Commutated Inverter, Phase Control Rectifiers, Cyclo-Converters and AC Voltage Regulators** because the supply is the **AC source** in all these converters.
- This method of **Commutation** is also called as **Source Commutation, or Line Commutation, or Class-F Commutation**. Because, in this method, the **Source of Commutation Voltage** is a supply source itself.

# Natural Commutation of SCR

- **Natural Commutation of SCR** is the process of **Turning-OFF** an SCR without using **Additional Commutation Circuitry**. This **Commutation Technique** only occurs in **AC Circuit**. For better understanding, let us consider an **SCR circuit** energized from **AC Source Voltage ( $V_s$ )** shown in **Figure (70)** below.

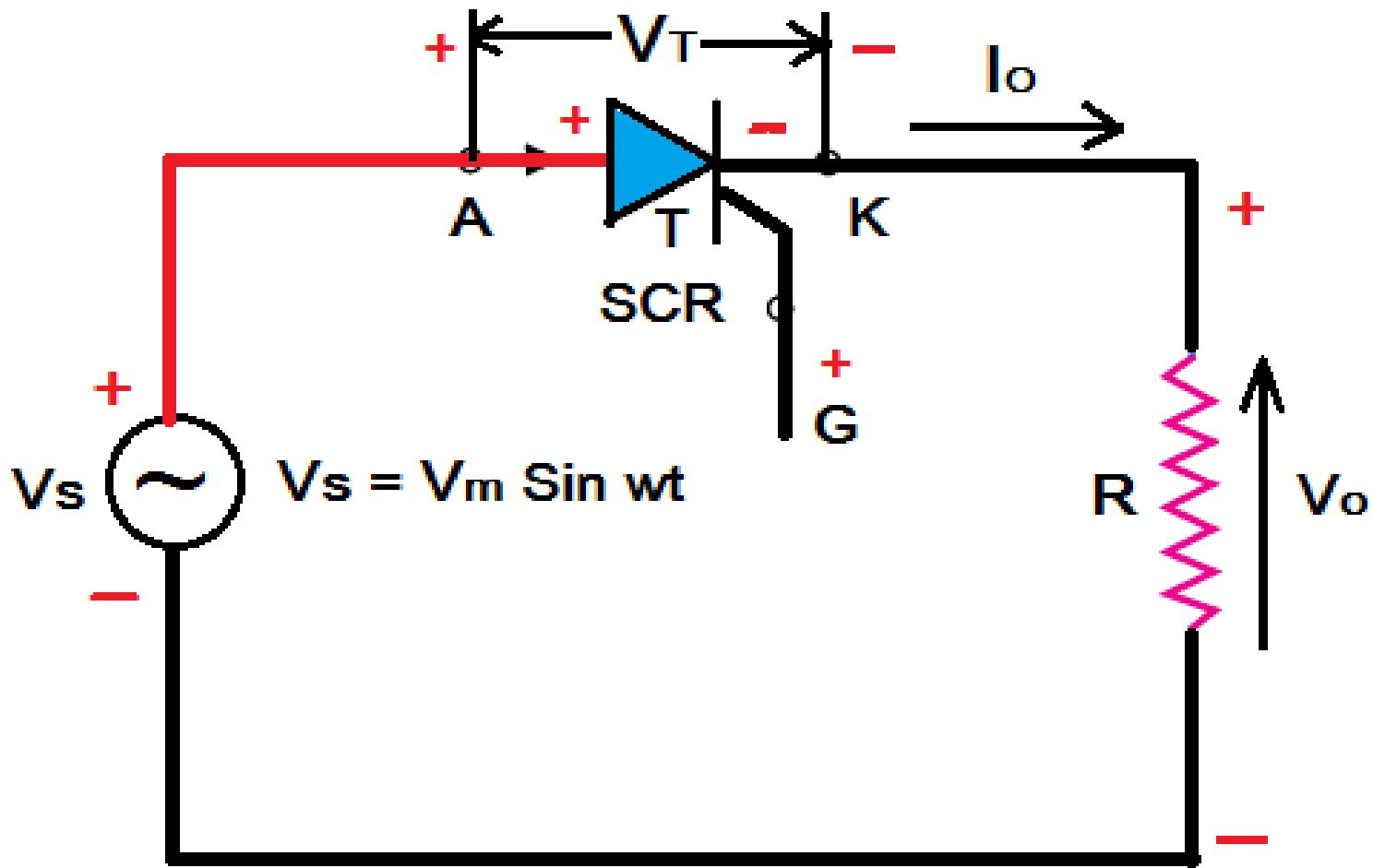

- **Fig (70)** Shown Natural Commutation or Line Commutation of SCR Circuit Diagram Energized from AC Source Voltage ( $V_s$ ).

- When we consider **AC supply**, **SCR is conducting**; the current will pass through zero crossing line after every **Positive Half Cycle**. After that, the **AC Source Voltage** then applies a **Reverse Voltage** across the **Anode to Cathode** terminals of **SCR** till the beginning of **Second Cycle**. If the time of application of **Reverse Voltage** applied by the **AC source** is more than the **SCR Turn-OFF Time**, then **SCR will Turned OFF Immediately**. This process is called as **Natural Commutation** as **SCR is Turned OFF Naturally** without using any external components or circuit or supply for **Commutation purpose**.

## Natural Commutation of SCR Explanation

- This type of **Commutation** takes place when supply voltage is AC, because a **Negative Voltage** will appear across the **SCR** in the **Negative Half Cycle** of the **Supply Voltage** and the **SCR Turns OFF** by itself. Hence no special circuits are required to **Turn OFF** the **SCR**. That is the reason that this type of **Commutation** is called **Natural** or **Line Commutation**.

- Let us understand the concept of **Natural Commutation of SCR** with the help of a simple circuit diagram as shown in **Figure (71)** below. **Figure (71)** shows the circuit where **Natural Commutation** takes place. From **Figure (71)**, a **SCR (thyristor) (T)** is connected to **Load (R)** and **AC Voltage Source (Vs)**. This SCR will not conduct until and unless it is **Forward Biased** and **Gate Signal** is applied. Application of **Gate Signal** is called **Firing**.

- We know that, there are **Two conditions** which must be satisfied for **Turn ON** of an **SCR**.

They are :-

- **(1) SCR must be Forward Biased i.e. its Anode (A) Terminal must be Positive with respect to Cathode (K) Terminal.**
- **(2) SCR must be Gated i.e. a Gate Signal must be applied across the Gate (G) and Cathode (K) Terminals.**

- This means, even though the **SCR is Forward Biased**, it is not going to **Conduct** until a **Gate Signal** is applied. This is not the case with a **Diode**. In a **Diode**, as soon as it gets **Forward Biased**, it starts **Conducting**. No **Gate Signal** is required to be applied for **Turning ON** a **diode**. In fact, there is no such **Gate terminal** in diode.
- Let us understand the concept of **SCR Firing and Firing Angle** in detail. For the sake of better understanding, consider the **Figure (71)** below.

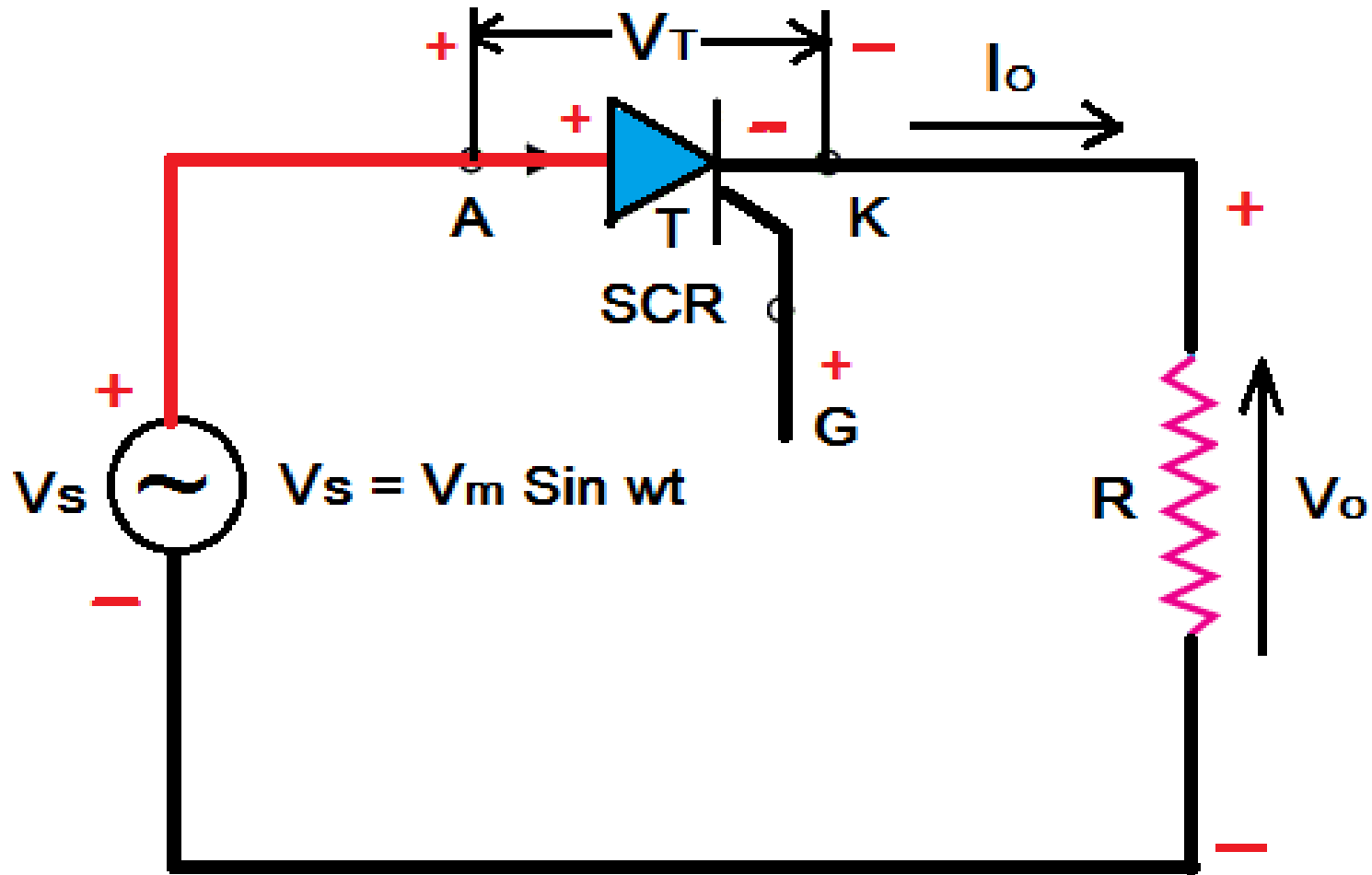

- **Fig (71)** Shown Natural Commutation or Line Commutation of SCR Circuit Diagram Energized from AC Source Voltage ( $V_s$ ).

- From the above **Figure (71)**, a SCR (thyristor) **T** is connected to **AC Source Voltage ( $V_s$ )** and **Load Resistance ( $R$ )**. Just think, if the **SCR (thyristor)** is replaced with a **diode**, it will start conducting for **Positive Half Cycle** of the **Supply Voltage ( $V_s$ )** as it is **Forward Biased** for this period as Shown In **Figure (72)** below.  
**But will it be the same case SCR (thyristor)?**

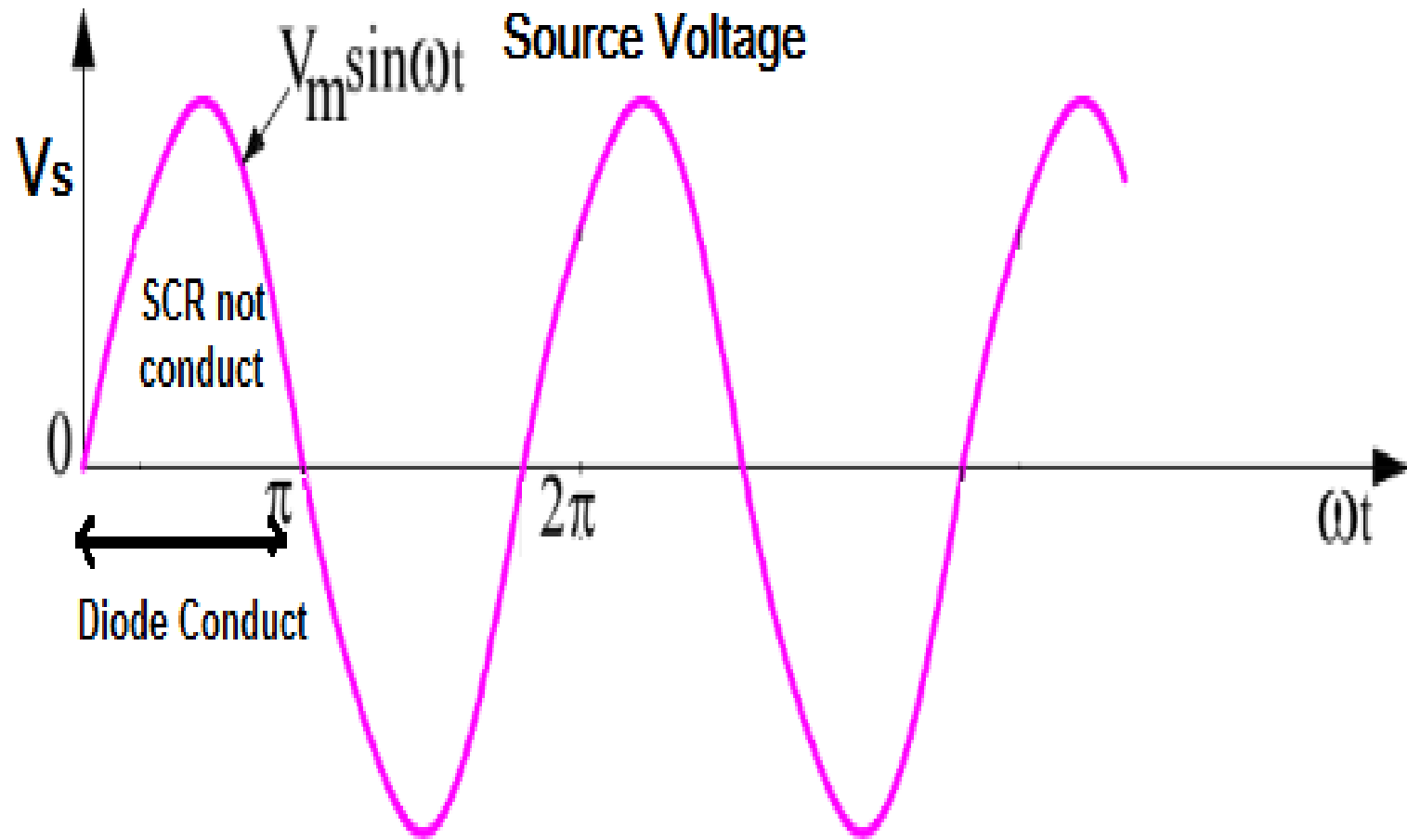

- **Fig (72)** Shown diode will start conducting for Positive Half Cycle of the Supply Voltage ( $V_s$ ) as it is Forward Biased but SCR not Conduct.

- **Obviously, No.** It's true that **SCR is Forward Biased for Positive Half Cycle** of the **Supply Voltage** but unfortunately **Gate Signal** is not applied. Hence, it will not **Conduct or Turn ON**. Let us now apply **Gate Signal** at some **angle  $\alpha$**  known as **Phase Angle**, on the **Source Voltage ( $V_s$ )** curve as shown in **Figure (73)** below.

## Phase Angle Definition

- Phase Control of SCR means having control on the phase relationship between the start of current through the SCR and source voltage.
- Whenever we talk of **Phase Angle**, we generally mean the angle of a sinusoidal quantity at any instant of time. Phase control of SCR means the phase angle (with reference to source voltage) where it is getting **Turned ON** by the application of **Gate Signal**.

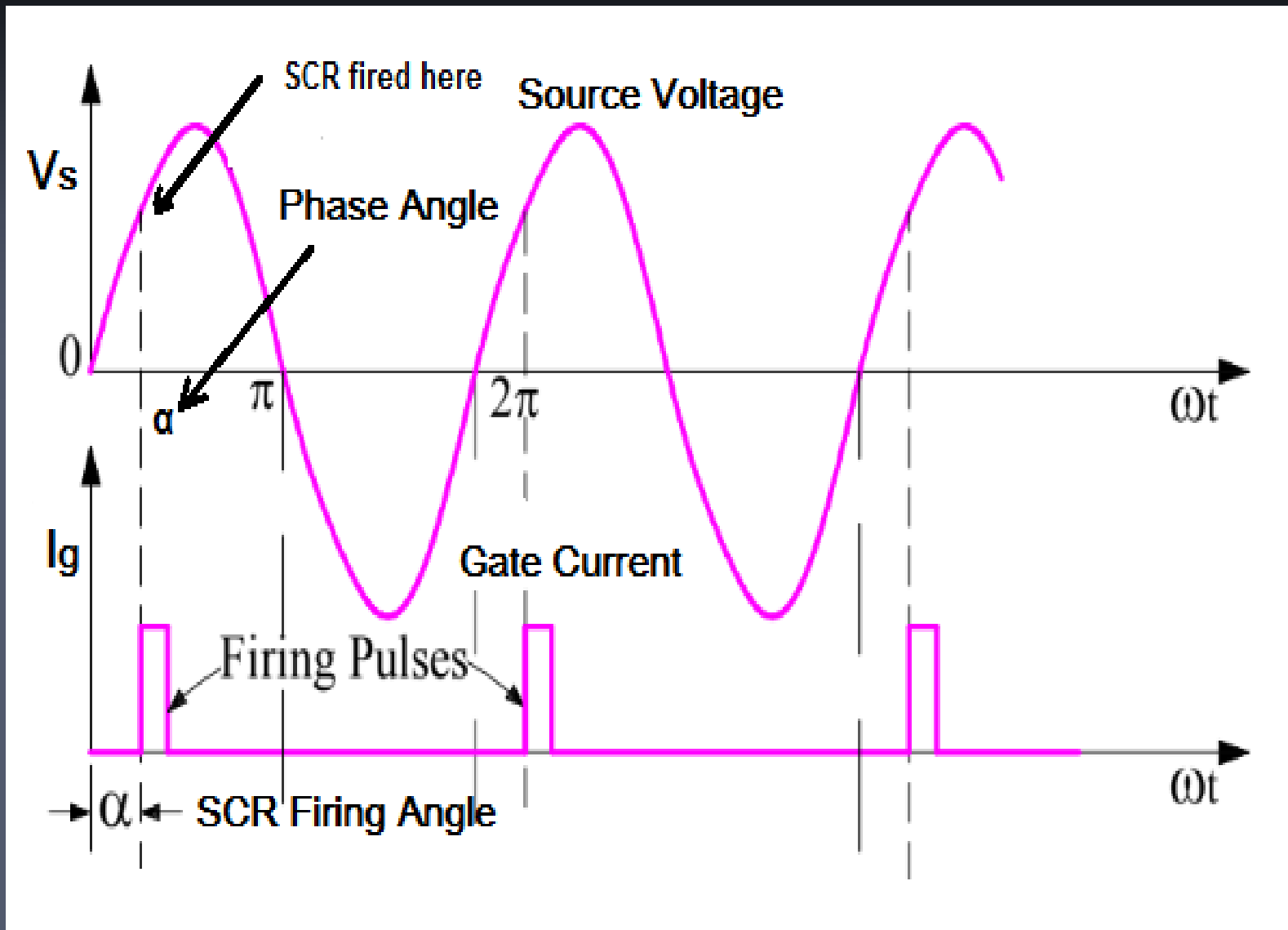

- **Fig (73)** Shown Gate Signal at some angle  $\alpha$  known as Phase Angle, on the Source Voltage ( $V_s$ ) curve.

- Let us now apply **Gate Signal** at some angle  $\alpha$  known as **Firing Angle**, on the **Gate Current ( $I_g$ )** curve as shown in **Figure (74)** below. Now, **SCR** is **Forward Biased** and **Gate Signal** is also **applied** at  $\omega t = \alpha$ . Hence, **SCR** will **Turn ON** and will start **Conducting**. This angle, at which **Gate Signal** is applied to **SCR Gate (G)** and **Cathode (K)** terminal is called **Firing Angle**. Application of **Gate Signal** is also called **Firing of SCR**.

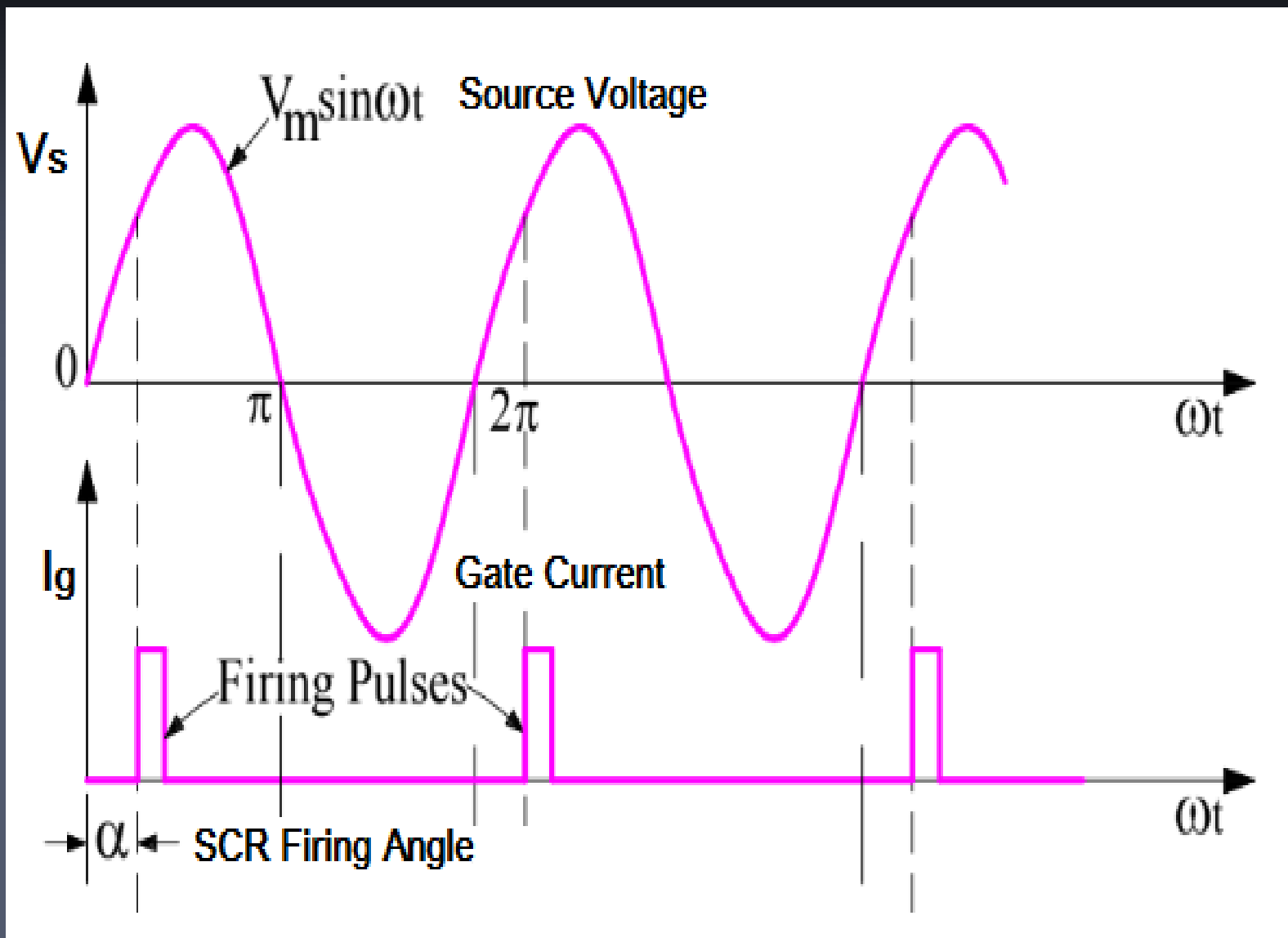

- **Fig (74)** Shown Firing Angle  $\alpha$  defined as the angle measured from the instant SCR gets forward biased to the instant it is triggered.

- During **Positive Half Cycle of Supply Voltage ( $V_s$ )** the **SCR is Forward Biased** and if the **SCR (thyristor) T** is fired (say at some **Phase Angle  $\alpha$**  on the **Source Voltage ( $V_s$ )**), it will become **ON**.
- As **SCR is now ON**, it will start **Conducting**. It will conduct from  $\omega t = \alpha$  to  $\pi$ . Since **Load is Resistive in nature**, the **Load Voltage ( $V_o$ )** and **Load Current ( $I_o$ )** will have a **waveform shape similar to Supply Voltage ( $V_s$ )**. The **Load voltage ( $V_o$ )**, **Load Current ( $I_o$ )** and **Supply Voltage ( $V_s$ )** waveforms are shown in **Figure (75)** below. **Now what happens next? Will SCR continue to conduct for an infinite time?**

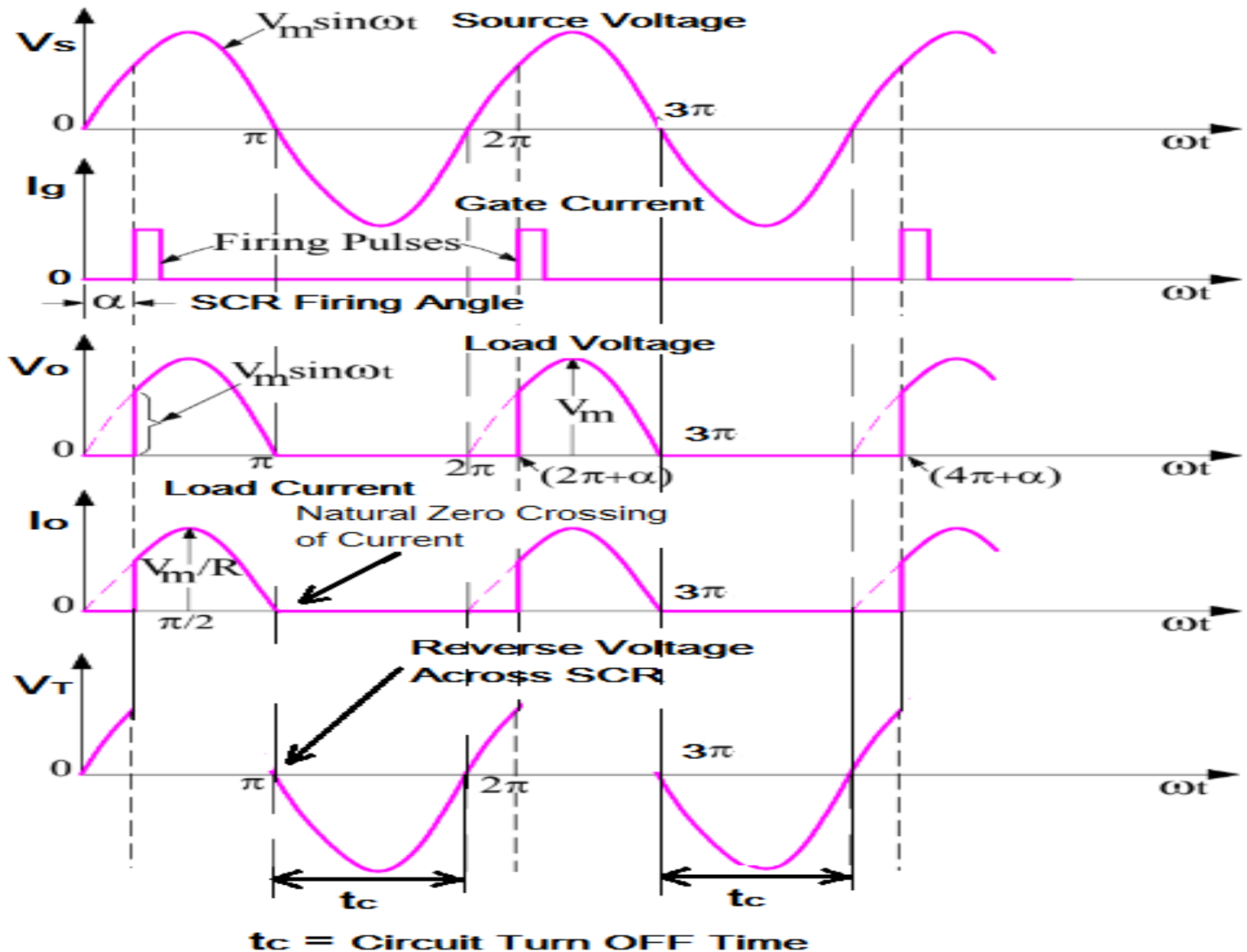

■ Fig (75) Shown the Natural Commutation or Line Commutation of SCR Circuit Waveforms.

- **It's Not So.** From **Figure (75)** shows the Natural Commutation or Line Commutation of SCR Circuit related waveform. At a **Delay Angle** of  $\omega t = \pi$ , **SCR (thyristor) T** will get **Commuated**, the **current** through the **SCR** will become **zero** as the load is **resistive in nature**. Then the **Load Current ( $I_o$ )** becomes **zero**. Further, after a **Delay Angle** of  $\omega t = \pi$ , the **Source Voltage ( $V_s$ )** becomes **Negative** and hence, the voltage across **SCR** also becomes **Negative**. Thus **SCR** is **Reversed Biased** from  $\omega t = \pi$  to  $\omega t = 2\pi$  i.e. for a **Time Period** of  $t_c = (\pi / \omega)$ . Therefore  $t_c$  is the time offered by the circuit within which the **SCR** should **Turn OFF** completely. **This time  $t_c$  is called Circuit Turn-OFF time.**

- If Circuit Turn-OFF Time  $t_c$  is more than the SCR Turn-OFF Time  $t_q$ , then SCR will get Turned-OFF. Therefore, the SCR will Turn OFF Naturally provided this Half Time Period should be greater than SCR Turn OFF Time. This technique of SCR Turn OFF is called Natural or Line Commutation.
- Thus  $t_c$  the Circuit Turn-OFF time should be greater than  $t_q$  the Turn OFF Time of the SCR. Otherwise, the SCR will become Forward Biased before it has Turned OFF completely and will Start Conducting even without a Gate Signal.

■ So, SCR will Turn OFF at Delay Angle of  $\omega t = \pi$ . To Turn ON SCR again, we need to fire it. Therefore, we again apply Gate Signal at  $\omega t = (2\pi + \alpha), (4\pi + \alpha), (6\pi + \alpha), \dots$ , so on. So there are several points where we are Firing the SCR. **Then what will be the Firing Angle?**

■ Since, the Source Voltage ( $V_s$ ) is Sinusoidal with a time period of  $2\pi$ , so Firing Angle will be “ $\alpha$ ”.

# Definition of Firing Angle

- Firing Angle of SCR is defined as the angle between the instant SCR would conduct if it were a Diode and the instant it is triggered.
- **OR**
- Firing Angle may also be defined as the angle measured from the instant SCR gets forward biased to the instant it is triggered. From this definition, the firing angle for our example is  $\alpha$ .

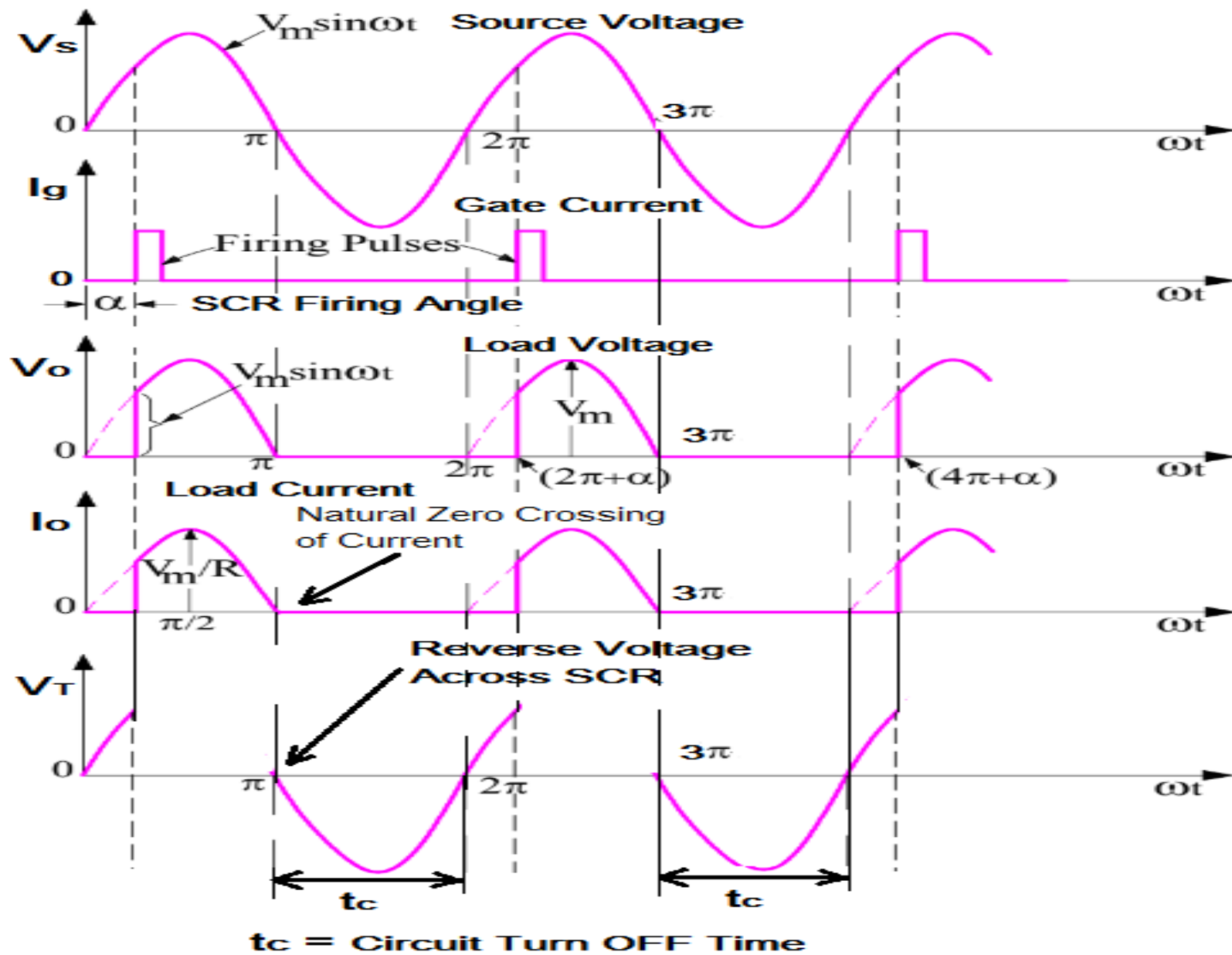

■ Fig (76) Shown the Natural Commutation or Line Commutation of SCR Circuit Waveforms.

- From above **Figure (76)**, Compare the waveform of Source Voltage ( $V_s$ ) and Load Current ( $I_o$ ). We will observe that, the SCR is getting turned ON at a Phase Angle of  $\alpha$ . Thus Phase Angle where SCR (thyristor) T starts conducting is dependent on firing angle. If Firing Angle  $\alpha$  is 0 degree, then Load Current ( $I_o$ ) and Source Voltage ( $V_s$ ) will be in Phase whereas if  $\alpha$  is 90 degree then Load Current ( $I_o$ ) will start when the Source Voltage ( $V_s$ ) is maximum. Thus the starting Phase Angle of Load is controlled by Firing Angle. *This must not be confused with the phase difference between the source voltage and current.*

- From the above discussion and observation of different waveforms, following points can be noted :-
  - (a) SCR is fired or gated at an Angle of  $\alpha$  called Firing Angle on the Source Voltage ( $V_s$ ).
  - (b) The waveform of Output Current ( $I_o$ ) or SCR Anode Current ( $I_o = V_o / R$ ) is Sinusoidal as the load is Resistive Load.
  - (c) When the AC Source Voltage reaches zero, at Delay Angle  $\omega t = \pi$ , SCR (thyristor) T will get Commuanted as the Load Current ( $I_o$ ) or SCR Anode Current becomes zero.

- **(d)** After Delay Angle  $\omega t = \pi$ , the Source Voltage ( $V_s$ ) becomes **Negative** and hence, the voltage across **SCR** also becomes **Negative**. Thus SCR is **Reversed Biased** from Delay Angle  $\omega t = \pi$  to  $\omega t = 2\pi$  i.e. for a Time Period of  $t_c = (\pi / \omega)$ . This time  $t_c$  is called **Circuit Turn-OFF** time.
- **(e)** If Circuit Turn-OFF Time  $t_c$  is more than the SCR Turn-OFF Time  $t_q$ , then SCR will get **Turned-OFF**.
- The above **SCR Turn OFF** process is known as **Natural Commutation** or **Line Commutation** of **SCR**.

- Thus we see from above that, the **SCR** is getting **Turned-OFF** due to the **Natural Tendency of AC**. This is the reason that this type of **Commutation Technique** is called **Natural Commutation**. It should also be noted that, no additional circuitry is required in this **Commutation Technique**. This **Commutation Technique** is basically the **Class-F Technique** which is also known as **Line Commutation of SCR**.

- This method of **Commutation** is also called as **Source Commutation, or Line Commutation, or Class-F Commutation**. This commutation is possible with **Line Commutated Inverters, Phase Control Rectifiers, Cyclo-Converters and AC Voltage Regulators** because the supply is the **AC source** in all these converters.

**to be continued .....**